

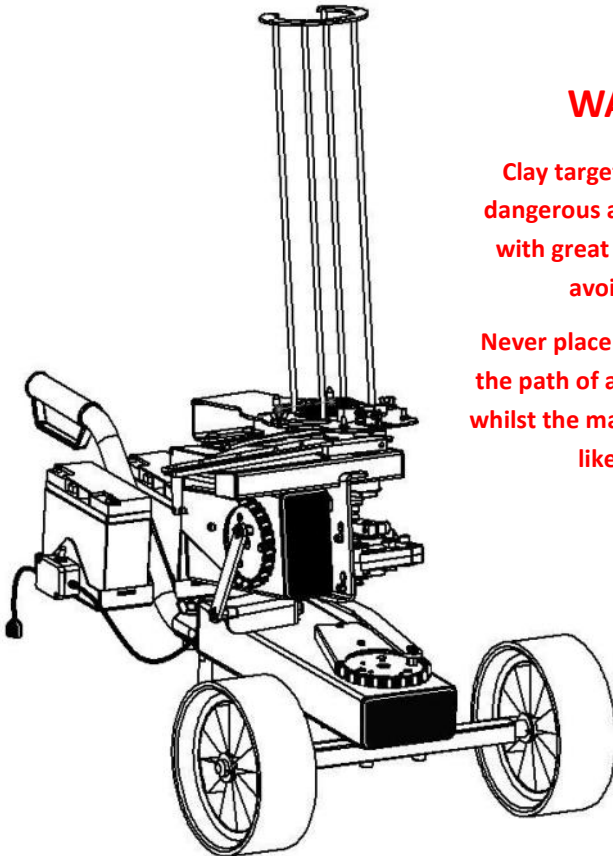

Operating Instructions Wobble units - Merlin & Hobby



WARNING

Clay target launchers can be dangerous and must be treated with great care at all times to avoid accidents.

Never place any bodily part into the path of any mechanical piece whilst the machine is in motion or likely to be so.

You must treat a clay target launcher with the same caution that you would treat a loaded gun. Assume at all times that a clay target launcher is armed and loaded and treat it accordingly



This document must be read in full before attempting to operate the machine



12v DC Power Source:

This product is designed to be powered from a 12v DC battery, it SHOULD NOT BE DIRECTLY CONNECTED TO HOUSEHOLD AC POWER

Battery: Where a trap is connected to any other suitable power source i.e. a Transformer - the relevant sections of instructions should still be observed, i.e. "Disconnect the battery" and applied to this or any other power source.

How the Rotation box fits into the trolley

The rotation box forms the basis of the trolley spine. A swivel piece mounted to this acts as a mount for the trap and replaces the trap's existing base or foot.

If the trap is currently fitted to a trolley it should be removed and the trolley disassembled from its spine as some of the existing trolley components (axle handle etc..) will be required to complete this assembly.

If the trap was mounted to a base then the kit purchased should also include the relevant trolley parts, please check that you have all the parts available.

Assemble the Rotation box to the existing trolley components:

Fit the trolley axle and wheels to the front (gear wheel) side of the rotation box.

Fit the extension tube to the rear end of the rotation box, followed by the trolley handle and ground spike using the clam-plates and fittings as shown below.

Fit second battery tray (Small battery version):

For traps using the budget trolley a second battery tray will need to be fitted. the second battery attaches to the opposite side of the pull handle as shown using the original nuts & bolts. Fit the nylon spacer piece to the rear holes so that it sits between the two trays using the extra nut & bolt provided.

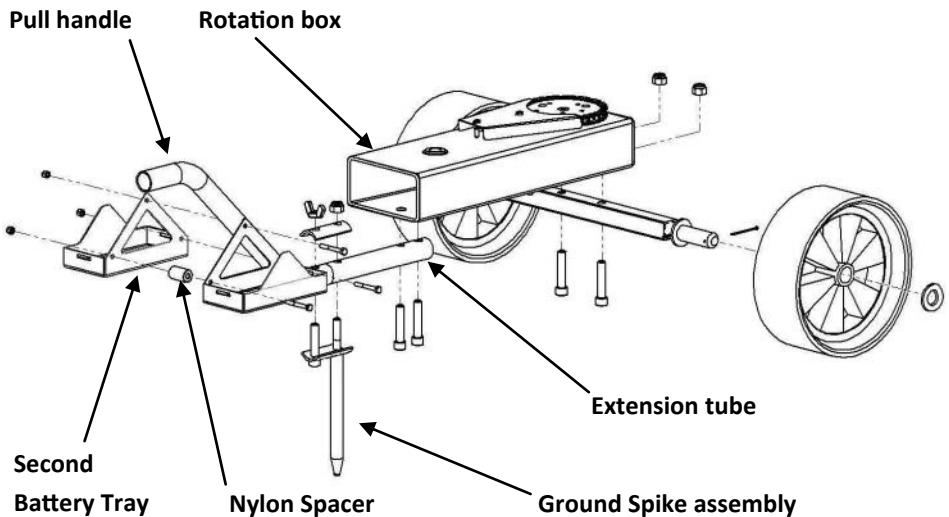

Assembling the optional kits:

Please read through the procedures for all the options you have purchased as some steps may need to be combined when fitting two kits.

The kits may be delivered with certain parts already pre-assembled.

Assemble the Elevation bracket

(For traps with the elevation option)

Fit the stud through the mounting hole in the swivel bracket and align the locating peg with the square hole fit the Large washer and nylock nut, tighten securely.

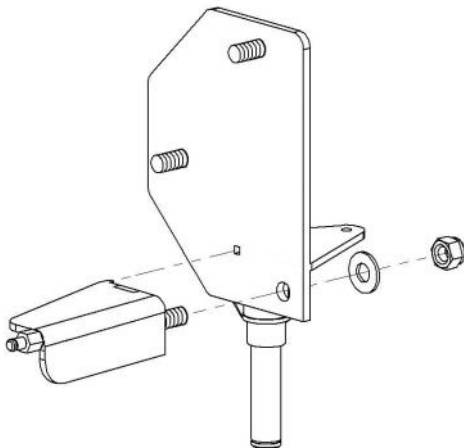

Connect linkage to rotation wheel

(All versions)

Fit the linkage to the swivel piece (trap base) then fit a washer below and secure with a spring clip. Fit the threaded spigot into any of the holes (other than the centre) of the rotating wheel. Fit a washer to the spigot.

Fit the other end of the linkage to the threaded spigot and secure with a spring clip.

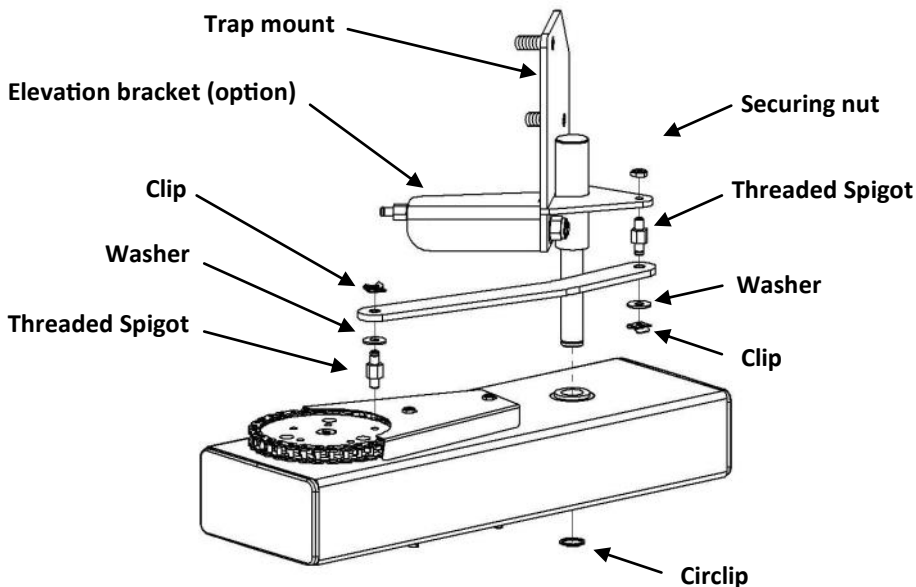

Install the electrical items and connect the battery:

Remove the motor cover on the underside of the rotation box .

The electrical assembly for the rotation box is supplied pre-fitted through the box end-cap, feed the two wires (one with the fuse assembly) through the rear of the box section.

Taking care not to damage the cable, fit the end cap into the rear of the rotation box with the cable gland towards the left-hand side (when viewed from the rear)

Fix the small switch box to the battery tray using the small strip of adhesive Velcro.

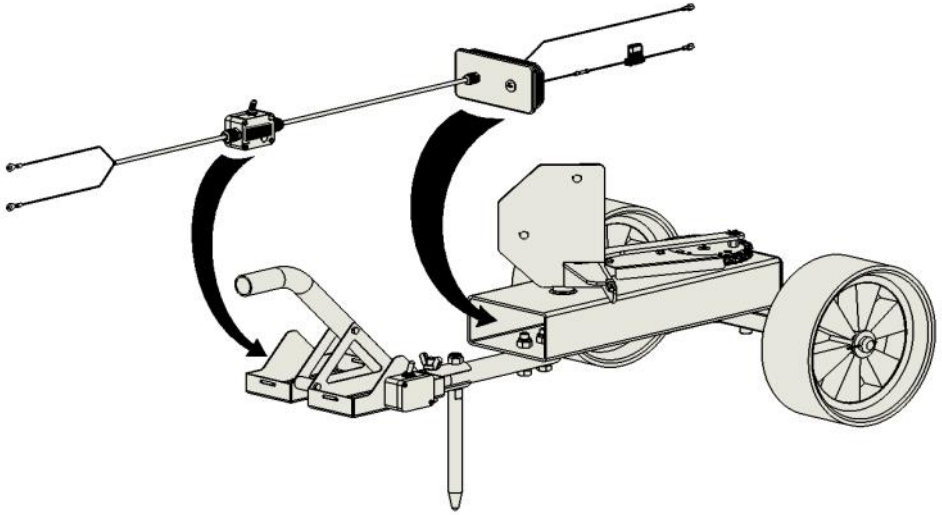

Connect the terminals to the rotation motor.

The connector with the black wire and the fuse holder fitted, should be connected to the larger of the two terminals, the connector with the blue wire to the smaller terminal.

Replace the motor cover and secure with the four screws previously removed, however If you have the elevation unit (optional) to fit - leave this cover off until later.

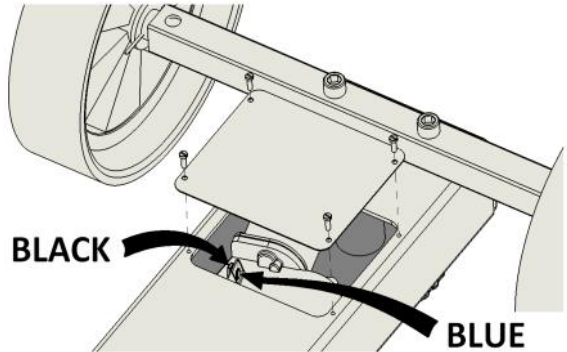

Install the second battery with the terminals facing in towards the handle. For Traps fitted with the large battery tray this step is not necessary as the ring terminals provided on the cable be connected to the appropriate existing battery connector

Connect the battery: Ensure that the switch is in the OFF (centre) position and connect the cables to the battery.

The Black wire connects to the + (or red coloured) battery terminal

The Blue wire connects to the - (or black coloured) battery terminal

Fitting the elevation unit:

If the elevation box is to be fitted the trap should now be mounted onto the trap carrier. Use a nylock nut and washer on the pivot point and the curved slot, tighten these until the trap can just pivot freely on the base without binding.

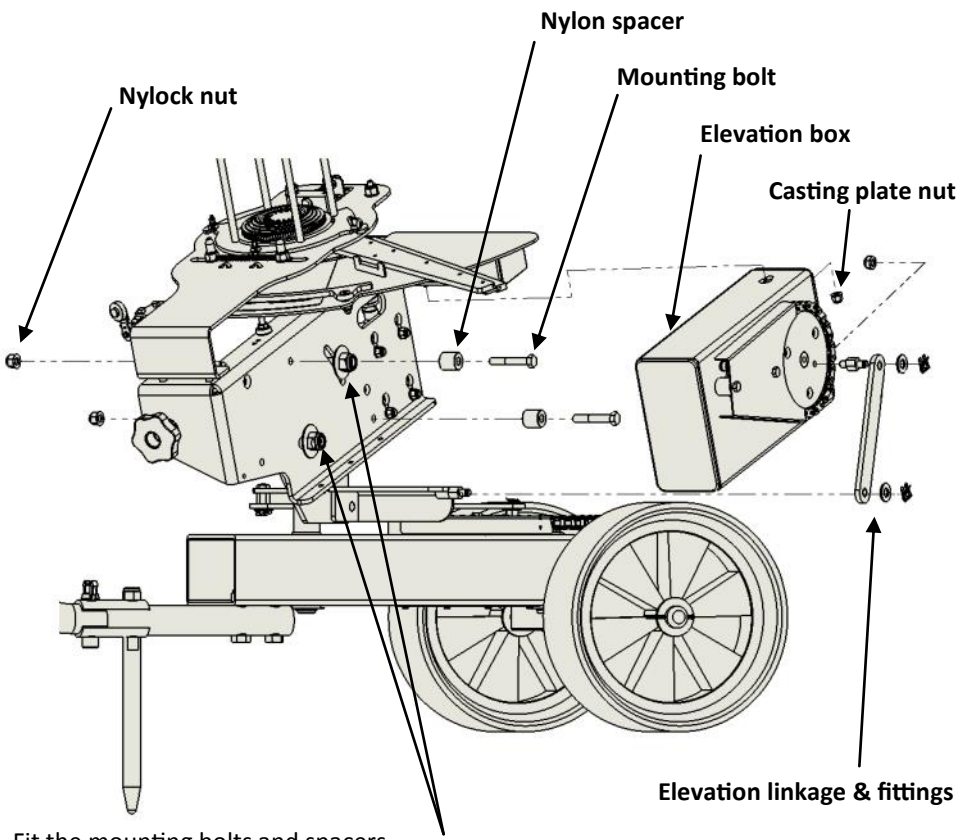

Fit the mounting bolts and spacers to the mainframe mounting holes as shown above, place a nylock nut on each and hand tighten only, at this stage the bolt heads need to remain protruding.

Undo but do not fully remove the forward casting plate nut, located under the rectangular frame support (nearest the main frame) allow around 10mm clearance under the nut to aid box location.

Remove the large black plastic plugs from the ends of the elevation box (taking care not to dislodge the electrical wiring from the motor) this will allow a clear view of the internal keyhole slots in the rear face of the box.

Trap fixing Nut & Washer

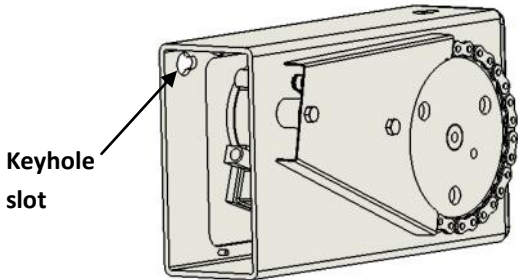

Fitting the elevation unit (continued):

Offer the box into position, fitting the keyhole slot on the rear box surface over the two bolt heads fitted earlier. Next rotate the box upwards into position and locate the front upper keyhole slot onto the casting plate nut loosened earlier. Finally slide the box rearwards to fully locate it.

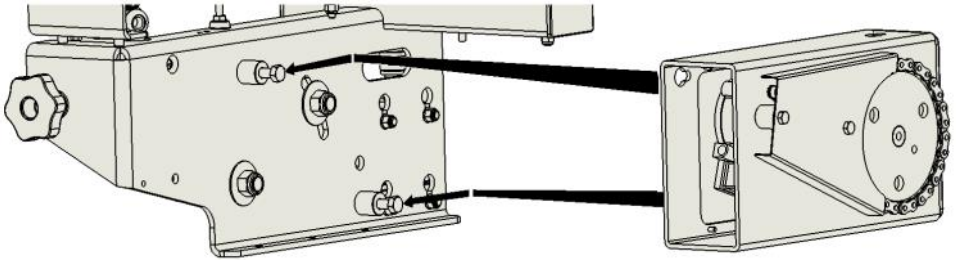

The two main fixing bolts can now be fully tightened, followed by the front casting plate nut. Refit the front and rear plastic caps, taking care not to trap the electrical wiring in the process.

Connecting the electrical wiring:

The elevation box is connected into the existing rotation box, undo and discard the white or light coloured blanking plug on the rotation box pass the wiring from the elevation box through into the rotation box. Once the cable is fitted to the required position, tighten the cable gland into the threaded hole (it may be necessary to slacken the rear part of the gland to allow it to spin on the cable during fitting)

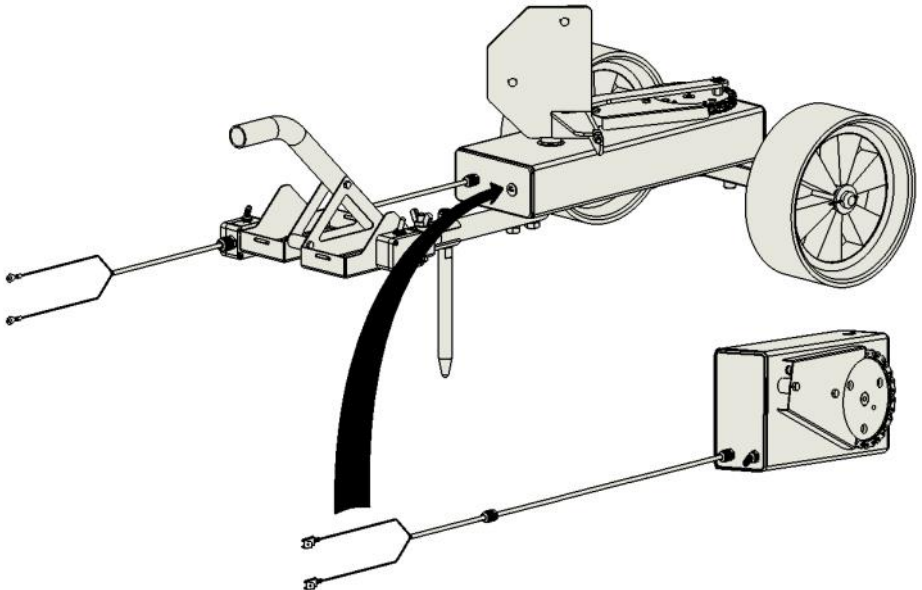

Connecting the electrical wiring (continued):

The wiring for the elevation unit is fitted with piggyback type connectors, and should be fitted to the existing motor connectors as shown below.

Replace any black plastic plugs in the ends of the elevation and/or rotation box (taking care not to trap the electrical wiring) and replace the motor cover using the four screws previously removed.

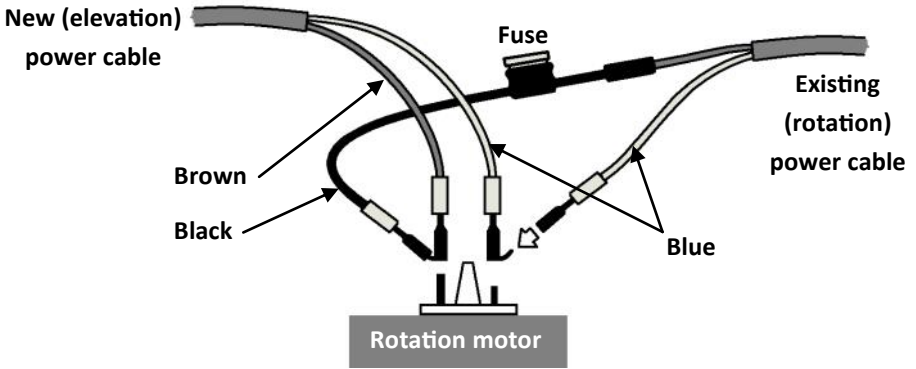

Elevation box wiring:

If the wiring to the elevation box has been removed for any reason, it should be reconnected as shown opposite.

The rotation disc on this box is intended to turn clockwise to ensure smooth operation.

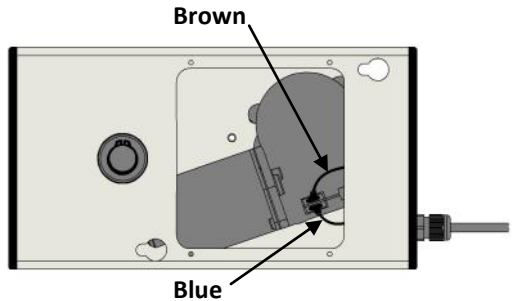

How to operate:

Setting the switch to the **ROTATION** position will allow to motor to run continuously varying the angle of the target. Pushing the switch forward to the **NUDGE** position will give a momentary burst (the switch will automatically spring back to the **OFF** position) this will allow a fixed trajectory to be selected.

Using the optional holes on the rotation disc a narrower or wider target field can be selected

The elevation function can be switched on and off independently using the switch on the back of the elevation box. Note: to set a fixed elevation it will be necessary to use the **NUDGE** function with the elevation box turned on until the target is thrown at the desired height, but please be aware that the trap will rotate as well during this procedure.

Once target is being thrown at the desired height the elevation function can be turned off leaving just the rotation function active.



Promatic International Ltd.

**Station Works,
Hooton,
South Wirral
CH66 7NF,
United Kingdom.**

Tel: +44 (0) 151 327 2220 (General)
+44 (0) 1407 860800 (Sales)
Fax: +44 (0) 151 3277075

E-mail info@promatic.co.uk

Website: www.promatic.co.uk

Promatic Inc.

**801 MID AMERICA DRIVE
PLATTSBURG, MO 64477
USA**

Toll Free: 888.767.2529
Fax: 816.539.0257

E-mail: sales@promatic.biz

Website: www.promatic.biz